

F627 High Flow Gas Regulator

The F627 pilot operated pressure reducing regulator provides superior performance when used in fixed-factor billing applications. The Type F627 includes a factory-installed PL81 pilot and has external registration that requires a downstream control line.

Features

- Accurate for Pressure-Factor Measurement Applications** — Pilot action controls pressure to within ± 1 percent of the absolute outlet pressure (PSIA) setting at full travel. This capability results in low-pressure variations over broad flow ranges and inlet pressure ranges.
- Wide Range of Flow Capabilities** — A variety of body and orifice sizes are available.
- Tight Shutoff Capability** — A flat disk of nitrile or fluorocarbon provides excellent shutoff capability.



Materials of Construction

F627 Main Regulator	
Body	Ductile Iron (Standard), Steel, LCC Steel
Spring Case and Diaphragm Case	Die Cast Aluminum (standard), or Steel
Orifice	Aluminum (Standard) or Stainless Steel
Disk Assembly	Aluminum (Standard) or Stainless Steel Holder with Nitrile Disk or Fluorocarbon Disk
O-rings and Diaphragm	Nitrile or Fluorocarbon
Tension Spring	Plated Steel
F627 Pilot Regulator	
Body	Aluminum
Spring Case	Aluminum
Diaphragm	Nylon Fabric Coated with Nitrile or Fluorocarbon
Valve Plug	Brass / Nitrile or Fluorocarbon
Stem Guide	Brass
Control Spring	Zinc Plated Steel
Valve Spring Plug	Aluminum
Pusher Post and Valve Plug Spring Seat	Aluminum
Diaphragm Plate, Spring Guide, and Adjusting Screw	Plated Steel

Minimum Pressure Differential

Actuator Spring	Color Code	Pilot Control Spring	
		5 to 35 PSIG (0.34 to 2.41 bar)	35 to 100 PSIG (0.34 to 2.41 bar)
High Differential	Silver	10 PSI (1.70 BAR)	10 PSI (1.70 BAR)
	Red	20 PSI (1.38 BAR)	20 PSI (1.38 BAR)

Specifications

Outlet Pressure Ranges		
Outlet	5 to 35 PSIG	0.34 to 2.41 BAR
	35 to 100 PSIG	2.41 to 6.90 BAR
Maximum Outlet (Casing) Pressure	250 PSIG	17.24 BAR
Maximum Inlet Pressure	250 PSIG (17.2 BAR) for all Type F627's EXCEPT 1/2" Orifice is 125 PSIG (8.62 BAR)	
Body Sizes	3/4 NPT (DN 20)	
	1 NPT (DN 25)	
	2 NPT (DN 50)	
Temperature Range	-20° to 180° F	(-29° to 82° C)
Weight Approximate		
NPT Body with Ductile Iron or Steel Casings	13 lbs	5.9 kg
NPT Body with Aluminum Casings	9.3 lbs	4.2 kg
Flanged Body with Ductile Iron Casings	18 lbs	8.16 kg
Flanged Body with Ductile Iron Casings	14 lbs	6.35 kg

F627 Part Matrix

F627									
									Port Size
	06								3/4"
	08								1"
	16								2"
									Spring Range
									PSIG BAR
	035								5 - 35 .34 - 2.4
	100								35 - 100 2.4 - 6.9
									Special Adders
		0							None
		1							Filter & Inlet Tube to Pilot Supply
		A							150 #RF*
		B							300 #RF*
		C							600 #RF*
		D							Socket Weld*
		J							150 #RF* with Filter and Tube
		K							300 #RF* with Filter and Tube
		L							600 #RF* with Filter and Tube
		M							Socket Weld* with Filter and Tube
									Restrictor Code
			1						High Gain
			2						Medium Gain
			3						Low Gain
									Orifice Size
			2						3/8" X 1/8"
			4						3/8" X 1/4"
			6						3/8"
			8						1/2"
									Seat and Diaphragm Material
			0						Nitrile
			2						Fluorocarbon
									Trim
			1						Aluminum (Standard)
			T						Stainless Steel
									Casing Material
			0						Aluminum Casing / Iron Body
			1						Steel Casing / Steel Body
			2						Aluminum Casing / Steel Body
			6						Aluminum Casing / LCC Steel Body
			7						Steel Casing / LCC Steel Body
			8						Steel Casing / Iron Body

* Steel or LCC Steel Bodies Only

F627 Regulator Rebuild Kits

	Kit Includes	Part Number
F627 Nitrile Standard Trim	Nitrile diaphragms (2), Nitrile valve disk, O-rings, back-up rings, and retaining pin	971F62700
F627 Nitrile Stainless Trim	Nitrile diaphragms (2), Nitrile valve disk, O-rings, back-up rings, and retaining pin	971F62701
F627 Fluorocarbon Standard Trim	Fluorocarbon diaphragms (2), Fluorocarbon valve disk, O-rings, back-up rings, and retaining pin	971F62702
F627 Fluorocarbon Stainless Trim	Fluorocarbon diaphragms (2), Fluorocarbon valve disk,, O-rings, back-up rings, and retaining pin	971F62703

F627 Maximum Allowable Inlet Pressure and Pressure Differential

ORIFICE SIZE INCHES (mm)	HIGH DIFFERENTIAL TENSION SPRING, RED COLOR CODE	
	LP Pilot	HP Pilot
	Maximum Inlet and Differential Pressure, PSIG (BAR)	Maximum Inlet and Differential Pressure, PSIG (BAR)
3/8 x 1/8 (9.53 x 3.18)	250 (17.2)	250 (17.2)
3/8 x 1/4 (9.53 x 6.35)	250 (17.2)	250 (17.2)
3/8 (9.53)	250 (17.2)	250 (17.2)
1/2 (12.7)	125 (8.62)	125 (8.62)

F627 Specifications

ORIFICE SIZE		ALLOWABLE INLET PRESSURE RANGE FOR MAINTAINING OUTLET PRESSURE WITHIN 1% OF THE ABSOLUTE OUTLET PRESSURE SETTING ⁽¹⁾									
		5 PSIG (0.34 BAR)		30 PSIG (2.07 BAR)		40 PSIG (2.76 BAR)		60 PSIG (4.14 BAR)		100 PSIG (6.90 BAR)	
Inch	mm	PSIG	BAR	PSIG	BAR	PSIG	BAR	PSIG	BAR	PSIG	BAR
3/8 x 1/8	9.5 x 3.2	30 to 250	2.1 to 6.9	55 to 250	3.8 to 17.2	65 to 250	4.5 to 17.2	85 to 250	5.9 to 17.2	125 to 250	8.6 to 17.2
3/8 x 1/4	9.5 x 6.4	30 to 250	2.1 to 6.9	55 to 250	3.8 to 17.2	65 to 250	4.5 to 17.2	85 to 250	5.9 to 17.2	125 to 250	8.6 to 17.2
3/8	9.5	30 to 250	2.1 to 6.9	55 to 250	3.8 to 17.2	65 to 250	4.5 to 17.2	85 to 250	5.9 to 17.2	125 to 250	8.6 to 17.2
1/2	12.7	25 to 125	1.7 to 8.6	50 to 125	3.4 to 8.6	60 to 125	4.1 to 8.6	80 to 125	5.5 to 8.6	120 to 125	8.3 to 8.6

1. For best performance, outlet pressure settings should be made using an inlet pressure that is midway between the highest and lowest expected inlet pressure.

F627 Flow Coefficients

Orifice Size		3/4-Inch Body			1-Inch Body			2-Inch Body		
Inch	mm	Wide-Open C_v for External Relief Sizing	C_v	C_1	Wide-Open C_v for External Relief Sizing	C_v	C_1	Wide-Open C_v for External Relief Sizing	C_v	C_1
3/8 x 1/8	3.2	12.5	0.43	29.1	12.5	0.45	29.4	12.5	0.45	29.2
3/8 x 1/4	6.4	50	1.63	30.6	50	1.70	29.3	52	1.70	31.3
3/8	9.5	108	3.00	36.1	108	3.70	31.6	115	3.40	33.9
1/2	12.7	190	4.80	39.0	190	5.30	35.9	200	5.30	39.9

Typical Performance Curve for 3/4-inch (DN 20) Type F627 Regulator

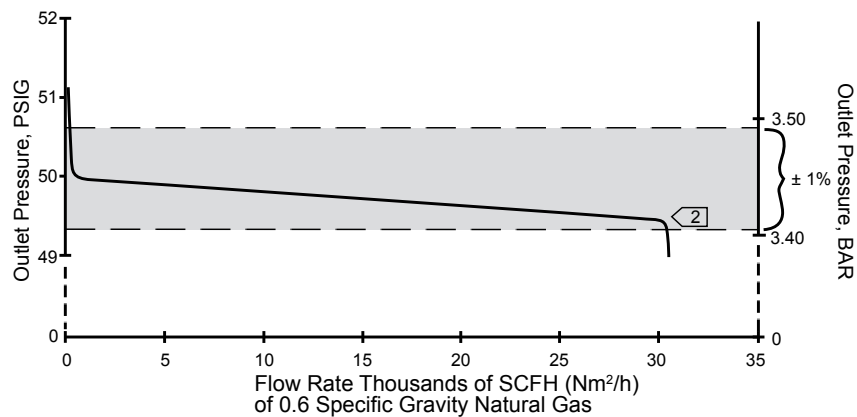

2 3/8-Inch (9.52 mm) Orifice.
 (Red Color Code) Actuator Spring 35 to 100 PSIG
 (2.41 to 6.90 BAR) Range (Red Color Code)
 Pilot Spring 200 PSIG Inlet Pressure (13.8 BAR) Inlet Pressure
 Medium Gain Restrictor

F627 Flow Capacities in SCFH (Nm³/h) of 0.6 Specific Gravity Natural Gas at 1% Droop in Absolute

Pilot Spring Range Part Number Color Code	Outlet Pressure Setting		Inlet Pressure		3/4" (DN 20) Body Size				1" Body Size				2" Body Size			
	PSIG	BAR	PSIG	BAR	Orifice Diameter, inches				Orifice Diameter, inches				Orifice Diameter, inches			
					3/8 x 1/8 (9.52 x 3.18)	3/8 x 1/4 (9.53 x 6.35)	3/8 (9.53)	1/2 (12.7)	3/8 x 1/8 (9.52 x 3.18)	3/8 x 1/4 (9.53 x 6.35)	3/8 (9.53)	1/2 (12.7)	3/8 x 1/8 (9.52 x 3.18)	3/8 x 1/4 (9.53 x 6.35)	3/8 (9.53)	1/2 (12.7)
5 to 35 PSIG (0.34 to 2.41 BAR) 655000154 Green	5	0.34	30	2.07	700	2840	5780	9730	700	2840	6040	10,100	700	2840	6150	10,100
			40	2.76	660	3500	7480	13,100	860	3500	7480	13,100	860	3500	7760	13,800
			50	3.45	1020	4140	8850	15,400	1020	4140	8850	15,400	1020	4140	9180	16,300
			60	4.14	1170	4780	10,200	15,500	1170	4780	10,200	17,800	1170	4780	10,600	18,800
			80	5.52	1490	6060	12,900	15,500	1490	6060	12,900	18,500	1490	6060	13,400	23,800
			100	6.90	1800	7340	15,500	15,500	1800	7340	15,700	18,500	1800	7340	16,300	28,900
			125	8.62	2200	8940	15,500	15,500	2200	8940	18,500	18,500	2200	8940	19,800	30,000
			150	10.3	2560	10,500	15,500		2590	10,500	18,500		2580	10,500	23,400	
	200	13.6	3370	13,700	15,500		3370	13,700	18,500		3370	13,700	30,000			
	250	17.2	4170	15,500	15,500		4170	15,500	18,500		4170	15,500	30,000			
	10	0.69	30	2.07	690	2760	5480	8500	690	2760	5480	8930	690	2760	5840	9500
			40	2.76	860	3500	7480	13,100	860	3500	7480	13,100	860	3500	7760	13,800
			50	3.45	1020	4140	8850	15,400	1020	4140	8850	15,400	1020	4140	9180	16,300
			60	4.14	1170	4760	10,200	17,800	1170	4780	10,200	17,800	1170	4780	10,600	18,800
			80	5.52	1490	6060	12,900	19,500	1490	6060	12,900	22,400	1490	6060	13,400	23,800
			100	6.90	1800	7340	15,700	19,500	1800	7340	15,700	22,600	1800	7340	16,300	28,900
			125	8.62	2200	8940	17,500	19,500	2200	8940	19,100	22,600	2200	8940	19,800	35,100
			150	10.3	2580	10,500	19,500		2580	10,500	22,500		2580	10,500	23,400	
	200	13.8	3370	13,700	19,500		3370	13,700	22,600		3370	13,700	30,500			
	250	17.2	4170	16,900	19,500		4170	16,900	22,600		4170	16,900	37,600			
	20	1.38	40	2.76	820	3250	6320	10,000	820	3250	6830	10,500	820	3250	6830	10,900
			50	3.45	1000	4030	8010	13,400	1000	4030	8500	13,400	1000	4030	8570	13,900
			60	4.14	1170	4780	10,200	17,800	1170	4780	10,200	17,800	1170	4780	10,600	18,800
			80	5.52	1490	6060	12,900	22,600	1490	6060	12,900	22,600	1490	6060	13,400	23,800
100			6.90	1800	7340	15,700	24,000	1800	7340	15,700	27,400	1800	7340	16,300	28,900	
125			8.62	2200	8940	19,100	28,000	2200	8940	19,100	33,300	2200	8940	19,800	35,100	
150			10.3	2580	10,500	22,500		2580	10,500	22,500		2580	10,500	23,400		
200			13.8	3370	13,700	28,000		3370	13,700	29,400		3370	13,700	30,500		
250	17.2	4170	16,900	28,000		4170	16,900	33,300		4170	16,900	37,600				
30	2.07	50	3.45	930	3680	7090	11,000	930	3650	7670	11,700	930	3630	7670	11,700	
		60	4.14	1140	4530	8880	14,800	1140	4530	9540	15,300	1140	4530	9540	15,300	
		80	5.52	1490	6060	12,900	22,600	1490	6060	12,900	22,600	1490	6060	13,500	23,800	
		100	6.90	1800	7340	15,700	27,400	1800	7340	15,700	27,400	1800	7340	16,300	28,900	
		125	8.62	2200	8940	19,100	33,300	2200	8940	19,100	33,300	2200	8940	19,800	35,100	
		150	10.3	2580	10,500	22,500		2580	10,500	22,500		2580	10,500	23,400		
		200	13.8	3370	13,700	28,000		3370	13,700	29,400		2370	13,700	30,500		
		250	17.2	4170	16,900	28,000		4170	16,900	36,200		4170	16,900	37,600		
35 to 100 PSIG (2.41 to 6.90 BAR) 655000155 Red	40	2.76	60	4.14	1030	4070	7770	10,400	1030	4070	8530	11,000	1030	4070	8440	12,000
			80	5.52	1450	5790	11,400	19,000	1450	5790	12,200	19,700	1450	5790	12,200	19,700
			100	6.90	1790	7340	15,700	27,400	1790	7340	15,700	27,400	1790	7340	16,300	28,900
			125	8.62	2200	8940	19,100	33,300	2200	8940	19,100	33,300	2200	8940	19,800	35,100
			150	10.3	2580	10,400	20,000		2560	10,400	22,500		2580	10,400	23,400	
			200	13.8	3370	13,500	20,000		3370	13,500	29,400		3370	13,500	30,500	
	50	3.45	70	4.83	1130	4450	8430	10,600	1130	4450	8460	11,200	1130	4450	8460	14,000
			80	5.52	1370	5420	10,500	17,000	1370	5420	11,400	17,900	1370	5420	11,300	17,900
			100	6.90	1770	7060	14,000	23,000	1770	7060	14,900	24,200	1770	7060	15,000	24,200
			125	8.62	2200	8940	19,100	33,300	2200	8940	19,100	33,300	2200	8940	19,800	35,100
			150	10.3	2580	10,400	22,500		2580	10,400	22,500		2590	10,400	23,400	
			200	13.8	3370	13,500	29,000		3370	13,500	29,400		3370	13,500	30,500	
60	4.14	80	5.52	1220	4790	9050	12,000	1220	4790	9860	12,900	1220	4790	9860	14,000	
		100	6.90	1700	6730	13,100	21,600	1700	6730	14,100	22,400	1700	6730	14,100	22,400	
		125	8.62	2170	8700	17,300	28,400	2170	8700	18,400	30,000	2170	8700	18,400	30,000	
		150	10.3	2580	10,300	22,500		2580	10,300	22,500		2580	10,300	23,400		
		200	13.8	3370	13,500	29,400		3370	13,500	29,400		3370	13,500	30,500		
		250	17.2	4170	16,900	32,000		4170	16,900	36,200		4170	16,900	37,600		
75	5.17	100	6.90	1490	5870	11,100	17,000	1490	5870	12,100	18,000	1490	5870	12,100	18,000	
		125	8.62	2080	8250	16,000	26,600	2080	8250	16,900	27,600	2080	8250	17,300	27,600	
		150	10.3	2550	10,200	20,300		2550	10,200	20,300		2550	10,200	21,700		
		200	13.8	3370	13,500	29,400		3370	13,500	29,400		3370	13,500	30,500		
100	6.90	125	8.62	1660	6680	12,500	18,000	1660	6680	13,700	19,400	1660	6680	13,700	21,200	
		150	10.3	2360	9320	17,800		2360	9320	19,400		2360	9320	19,400		
		200	13.8	3330	13,400	26,000		3330	13,400	28,300		3330	13,400	28,500		
		250	17.2	4170	16,900	36,000		4170	16,900	36,200		4170	16,900	37,600		

- High Differential Actuator Spring
 - Maximum Operating Inlet Pressure is Exceeded

F627 Dimensions

Aluminum/Cast Ductile Iron Units

Type	Body Size		A	B	C	D	E	F*	K
F627	3/4"	mm	104	254	247	26	3/4"	190	152
		inches	4.08	10.0	9.75	1.0		7.5	6.0
	1"	mm	104	254	247	26	1"	190	152
		inches	4.08	10.0	9.75	1.0		7.5	6.0
	2"	mm	127	267	247	43	2"	216	152
		inches	5.0	10.5	9.75	1.69		8.5	6.0

*F Dimensions for steel P627 - 120 mm / 4.7 inches

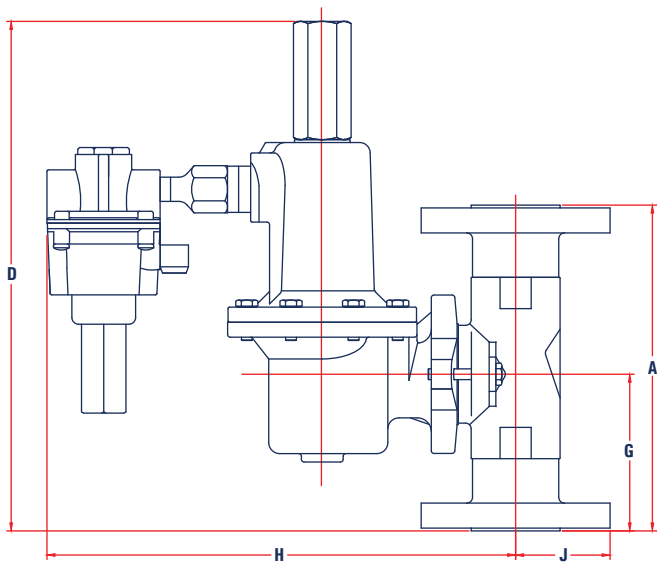
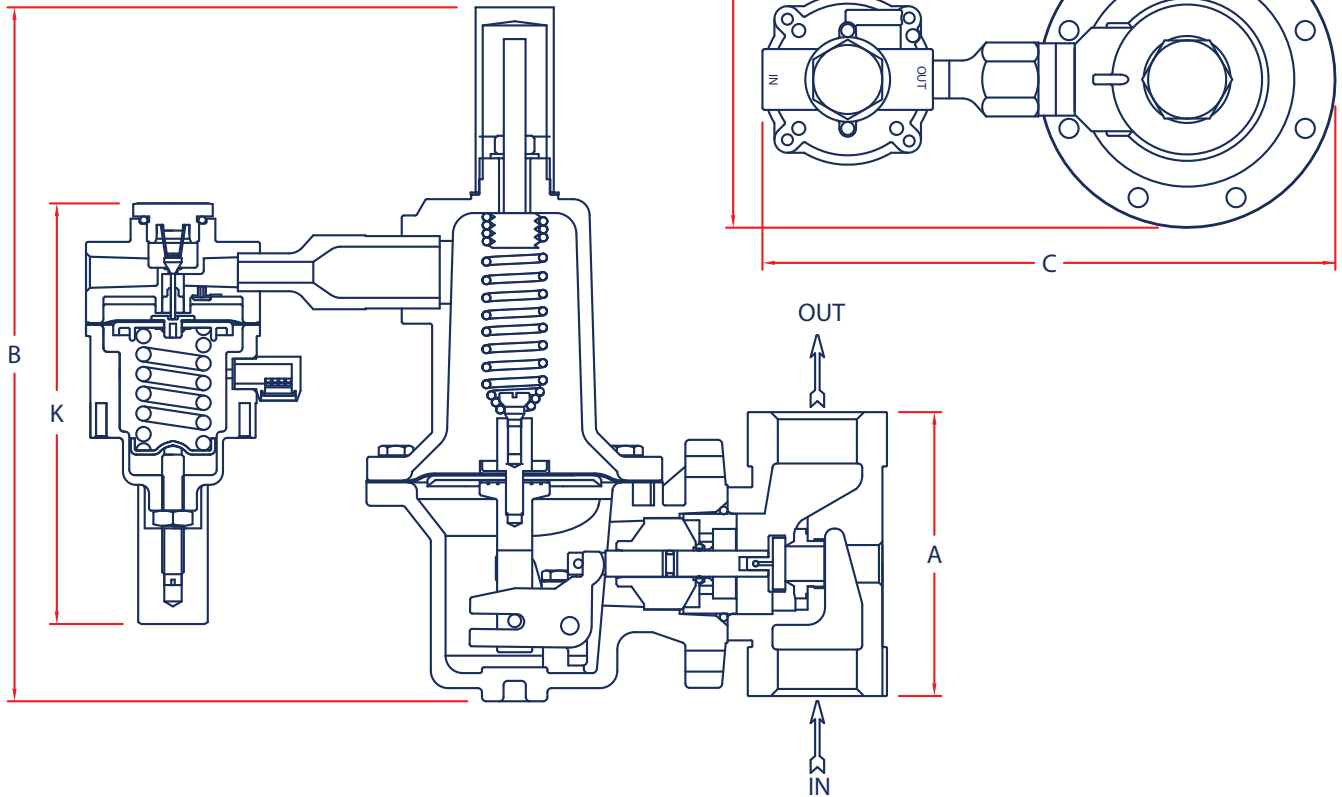

F627 Dimensions

Flange Units

Type	Body Size	A			D			G			H	J			
		150 RF	300 RF	600 RF	150 RF	300 RF	600 RF	150 RF	300 RF	600 RF		Steel	150 RF	300 RF	600 RF
F627 Flanged Units	1"	mm	184	197	210	297	297	297	91.9	98.6	105	168	53.8	62.0	62.0
		in.	7.25	7.75	8.25	11.7	11.7	11.7	3.62	3.88	4.12	6.62	2.12	2.44	2.44
	2"	mm	254	267	286	297	297	297	127	133	143	168	76.2	82.5	82.5
		in.	10	10.5	11.25	11.7	11.7	11.7	5	5.25	5.62	6.62	3	3.25	3.25

F627 Parts

Item	Description	Part Number
1	Closing Cap, Aluminum	610-068-000
32	Closing Cap Gasket	624-082-000
2	Spring Seat Bolt	648-541-000
33	Spring Retainer Screw	648-542-000
3	Locknut	634-000-112
4	Bonnet, F627 - Aluminum	604-210-000
	Bonnet, F627 - Steel	604-561-000
7	Tension Spring	655-745-000
8	Diaphragm Piston	637-306-000
	Diaphragm Standoff	637-020-000
	Diaphragm Nylon Gasket	624-083-000
	Piston Retainer	643-191-000
	Post, Pusher F627	827-005-000
	Diaphragms	
	Diaphragm F627 Aluminum (Nitrile)	618-069-000
	Diaphragm F627 Aluminum (Fluorocarbon)	618-069-001
9	Build Screw, Spring Case - Aluminum (8 required)	648-466-000
	Build Screw, Steel (8 required)	648-467-003
10	Diaphragm Cases	
	Diaphragm Case - Aluminum	629-202-000
	Diaphragm Case, Aluminum (for Steel body)	629-215-000
	Diaphragm Case, Steel	629-203-000
11	Lever	703-004-000
12	Lever Screw (2 required)	648-466-002
13	Pin, Lever	635-053-000
14	Lever Retainer	643-192-000
15	Stem O-ring, Nitrile	649-000-003
	Stem O-ring, Fluorocarbon	649-000-343
16	Stem Backup Ring, TFE (2 required)	644-047-000
17	Pin, Groove	635-054-000
18	Stem Guide	626-083-000
19	Pin Clip	635-055-000
20	Stem, 316SS	689-005-000
30	Diaphragm Case O-ring, Nitrile	649-280-000
	Diaphragm Case O-ring, Fluorocarbon	649-280-001
21	Boost Body F627	686-005-000
22	O-ring - Nitrile	649-000-213
	O-ring - Fluorocarbon	010-380-003
23	Seat Assemblies	
	Seat assembly - aluminum holder/nitrile disk	822-019-000
	Seat assembly - aluminum/Fluorocarbon	822-040-000
	Seat assembly - 316SS holder/nitrile	822-020-000
	Seat assembly - 316SS/Fluorocarbon	822-040-001
24	Orifice - Aluminum	
	3/8" x 1/8"	688-059-001
	3/8" x 1/4"	688-059-000
	3/8"	688-013-001
	1/2"	688-013-000
	Orifice - 316SS	
	3/8" x 1/8"	688-060-001
	3/8" x 1/4"	688-060-000
3/8"	688-014-001	
1/2"	688-014-000	

Item	Description	Part Number
25	Bodies	
	Iron - 3/4" NPT	664-560-000
	Iron - 1" NPT	664-560-001
	Iron - 2" NPT	664-563-000
	Steel - 3/4" NPT	664-559-000
	Steel - 1" NPT	664-559-001
	Steel - 2" NPT	664-564-000
	LCC - 3/4" NPT	664-569-000
	LCC - 1" NPT	664-569-001
	LCC - 2" NPT	664-565-000
	Steel - 3/4" Socket Weld	664-566-000
	Steel - 1" Socket Weld	664-567-000
Steel - 2" Socket Weld	664-568-000	
27 (Not Shown)	Build Screw, 3/4" & 1" aluminum unit	648-466-001
	Build Screw, all steel bodies	648-467-001
	Build Screw 2" aluminum unit (2 required)*	648-466-003
28	Name Plate Drive Screw (2 required) (not shown)	648-464-000
34	Bonnet/Pilot Reducing Nipple	633-023-000
29	Locking Nut	662-000-016
5	Locking Washer	662-000-152
6	PL81 Pilot Regulators	
	LP Standard Gain - Nitrile	832-032-000
	LP Low Gain - Nitrile	832-032-001
	LP High Gain - Nitrile	832-032-002
	LP Standard Gain - Fluorocarbon	832-032-003
	LP Low Gain - Fluorocarbon	832-032-004
	LP High Gain - Fluorocarbon	832-032-005
	HP Standard Gain - Nitrile	832-032-006
	HP Low Gain - Nitrile	832-032-007
	HP High Gain - Nitrile	832-032-008
	HP Standard Gain - Fluorocarbon	832-032-009
	HP Low Gain - Fluorocarbon	832-032-010
HP High Gain - Fluorocarbon	832-032-011	

F627 Parts

